

DEVILBISS

SB-E-8-305 ISS.07



OPERATION MANUAL

DVFR-1 Air Filter Regulator



Operation Manual

DVFR-1 Air Filter Regulator

Important



Read and follow all instructions and Safety Precautions before using this equipment

Description

A compact Air Filter Regulator suitable for 1 or 2 operators, designed to remove entrained dirt, liquid oil and water from flowing compressed air, and to regulate the air pressure to enable air using devices to be operated.

Regulator is a self relieving design that senses over-pressure at the regulated outlets and vents excess pressure to atmosphere. The rolling diaphragm improves pressure sensitivity adjusting the valve for fluctuating airflows and pressures.

Model

Order No. DVFR-1 Filter regulator unit. Complete with air pressure gauge and mounting bracket.

Specifications

Air supply connection	1/2" BSP female.
Air outlet connections	1/4" BSP male.
Gauge port	1/8" BSP female.
Size width	175 mm
height	280 mm

Weight	2.5 kg
--------	--------

Maximum:	
air flow	3550 l/min
air supply pressure	13 bar
regulated air pressure	0-8 bar
operating temperature	100° C

Filter aperture size	5 micron
----------------------	----------

Typical pressure drop	0.75 bar
-----------------------	----------

Parts List

Ref No	Part No	Description
1	DV-9450806	Upper Cover Assembly including diaphragm
2	DV-9451705	Replacement Filter Element (5 microns)
3	DV-9453301-MET	Metal Filter Bowl with drain valve
4	SER-3414-MF	Ball Valve 1/4 inch BSP (m) & (F)
5	GA-319	Pressure Gauge 0-160 psi
6	DV-8000035	Isolation Valve

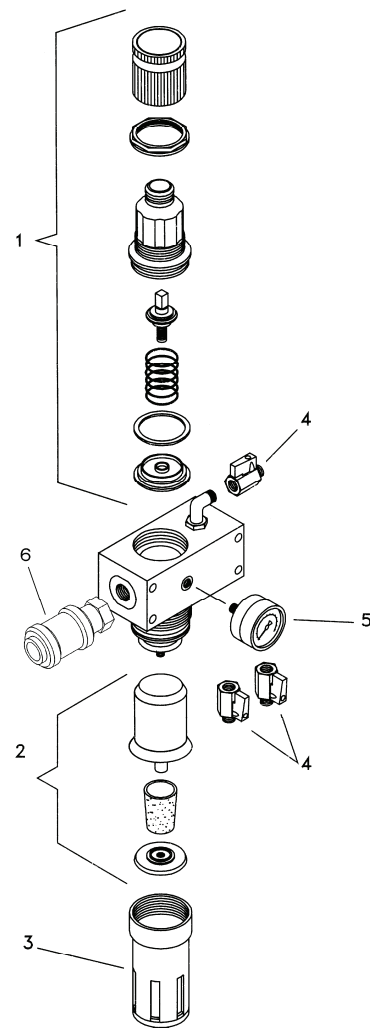



SAFETY WARNINGS



Misuse

- Never exceed the recommended safe working pressure/temperature for any of the equipment used.
- Do not use paint solvents to clean the unit or filter element.
- The fitting of non- recommended or non- original accessories or spare parts may create hazardous conditions.
- Do not install the unit above electrical or any other equipment that will be damaged by discharged condensate.
- Before dismantling the equipment for cleaning or maintenance, all air pressures must be isolated and released.
- When assembling an air pressure gauge to the unit DO NOT use a spanner, always tighten by hand.
- The disposal of non-metallic materials must be carried out in an approved manner. Burning may generate toxic fumes.

Installation / operation

1. Always install the unit so that the air flows in the direction indicated by the arrows on the body.
2. Install the unit as near as possible to the point of use.
3. Always depressurise the unit before periodic maintenance and installation.
4. Ensure the earth lead is connected to an earth point and verify continuity from each ball valve (item 4) to another known earth point, a resistance of less than 1k ohm should be achieved for dissipation of electrostatic charge.
5. An isolation valve is fitted (6) to the inlet of the unit to allow condensate to be drained and for ease of maintenance. Slide to the right towards the regulator to open. Slide to the left to close.
6. When reducing the pressure, always turn the regulator below the required pressure and adjust upwards. When assembling the pressure gauge to the unit always tighten by hand. DO NOT USE A SPANNER. (Fig 6).
7. To lock the regulator press the adjusting knob down . To release the lock lift the knob up.
8. The condensate drain valve on the bottom of the filter can be used semi-automatically or manually.
 - a) With the push button in the central position the valve is semi-automatic (i.e. when the filter bowl is depressurised the valve will open allowing the condensate to drain from the bowl). When the bowl is pressurised the drain valve will automatically close.
 - b) If necessary, it is possible to drain the condensate while the filter bowl is pressurised. To do this, the simple operation of pushing the valve up will open the drain and release the condensate.
 - c) By rotating the button clockwise, the valve becomes locked closed. Drainage is impossible in this position and can only occur when the button is returned to the central position.

Note: To unscrew the bowl from the unit , use a compass key (pin spanner) with 2 mm diameter pins.

Maintenance

Cleaning: The filter element can be removed and cleaned, by removing condensate bowl and unscrewing tie rod.

It is recommended that filter/coalescer elements are replaced periodically i.e. when a drop in pressure is noticeable through the unit or every 6 months.

Ensure earthing of the unit is not affected by maintenance activities , see installation above.

Finishing Brands UK Limited,
Ringwood Road,
Bournemouth,
BH11 9LH,
UK.
Tel.No. +44 (0)1202) 571111
Fax No. +44 (0)1202) 581940,
Website address [http:// www.finishingbrands.eu](http://www.finishingbrands.eu)

Registered office:
Finishing Brands UK Limited,
400, Capability Green,
Luton,
Bedfordshire,
LU1 3AE,
UK.
Registered in England: No. 07656273 Vat No. GB 113 5531 50

May 12